

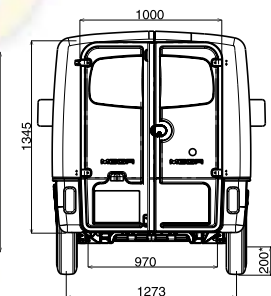

Dimensions (mm)

Wheel base	2 325
Overall length	3 328
Overall width (excluding rear view mirrors)	1 490
Overall height*	1 830
Bed interior length	1 505
Min. interior width	900
Max. interior width	1 415
Interior height (diesel)*	1 468
Interior height (AGM batteries - maintenance free)*	1 368
Interior height (flooded batteries)*	1 298
Interior volume (m3)	approx. 3
Height load (diesel)*	380
Height load (AGM batteries - maintenance free)*	480
Height load (flooded batteries)*	550
Rear doors opening width	1 000
Rear doors opening height	970
Height from ground to trunk floor	1 345
Front ground clearance*	155
Rear ground clearance*	200
Front track	1 299
Rear track	1 273
Rear overhang	560

* Unladen vehicle ± 20mm

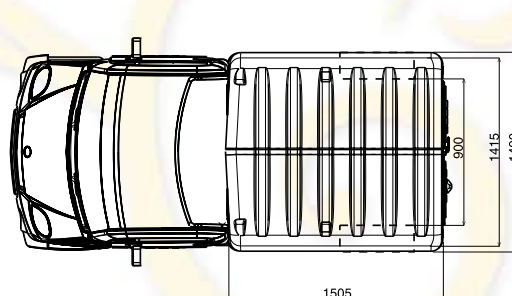
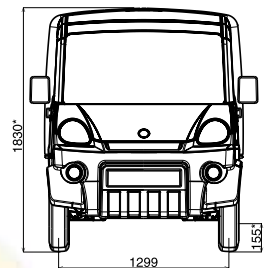
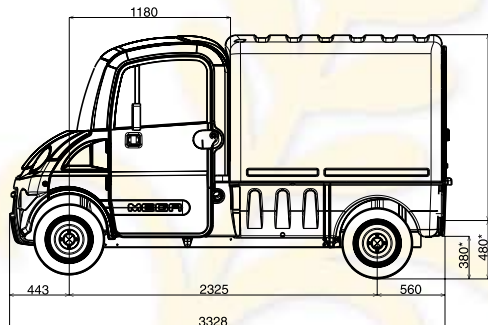

4 colours choice:



Weight (kg)

	Multitruck Diesel 400	Multitruck Diesel 600	Multitruck AC Power flooded batteries	Multitruck AC Power AGM batteries (maintenance free)	Multitruck Electric - no licence version**	Worker
Payload*	up to 625 kg					
Van finishing equipment weight	85					55
Max. tolerated load on Front axle	390	475	520	520	520	530
Max. tolerated load on Rear axle	450	690	690	690	690	900
Loaded trailer (without brakes) max. weight	NA					750
Loaded trailer (with brakes) max. weight	NA					1 017
Maximum weight on hook	NA					30
Total authorised weight on road including trailer weight	NA					1 800

* Includes load, driver, passenger, finishing equipment, options and accessories weights - Refer to basic version technical data sheet.

** In France

Standard equipment

- Basic version equipment
- White van cell (fiber glass polyester)
- 2 rear lockable doors

Optional equipment

- Rear door windows
- Left or Right side door (dim. 565x1285 mm)
- Presence bell (all electric versions)
- Run time meter (standard in Worker)
- Trim hooks
- Radio CD/MP3/RDS
- Wood floor (combustion engine versions)*
- Side impact bars
- Rear impact bar
- Flashing beacon
- Roadsign bar (with 2 beacon lights)
- Reflecting tapes
- Diesel additional heating system (all electric versions)
- Reversing buzzer (combustion engine version)*

*standard on electric versions

Worker options

- Doors
- Fan and electric heating system
- Additional Converter 48V/12V 300W
- Tow bar



Right side door (or also available left side door)



Rear door windows



Spacious cabine



Rear impact bar



Wood floor



Side impact bars

OMD004GB - This document is non-contractual. Certain details on the vehicles supplied can be different from those photographed. We decline all responsibility in case of fault or omission in this document. 10/09