

## ecOLOGIC

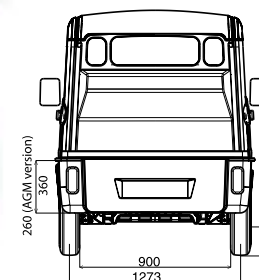

### Dimensions (mm)

Wheel base	2 325
Overall length	3 288
Overall width (excluding rear view mirrors)	1 487
Overall height*	1 800
Bed interior length	1 520
Bed interior width	1 377
Tailgate width	900
Bed height (diesel)	360
Bed height (AGM batteries - maintenance free)	260
Bed height (flooded batteries)	190
Height load (diesel)*	380
Height load (AGM batteries - maintenance free)*	480
Height load (flooded batteries)*	550
Front ground clearance*	155
Rear ground clearance*	200
Front track	1 299
Rear track	1 273
Rear overhang	520

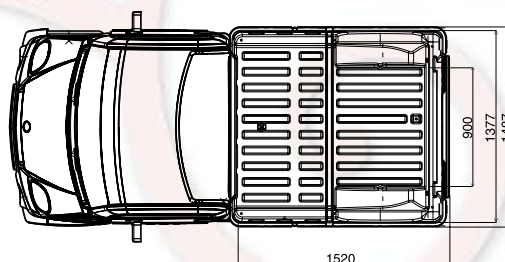
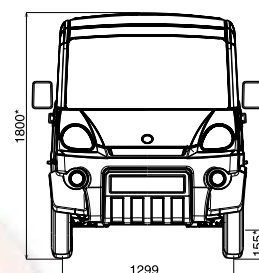
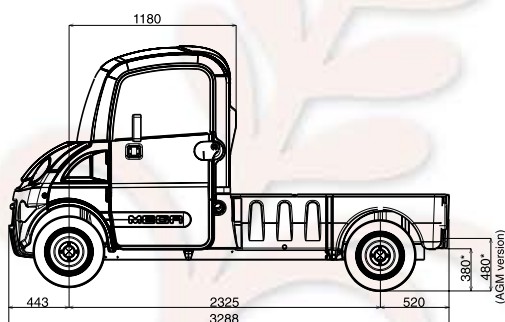

\* Unladen vehicle ± 20mm

4 colours choice:



## Weight (kg)

	Multitruck Diesel 400	Multitruck Diesel 600	Multitruck AC Power flooded batteries	Multitruck AC Power AGM batteries (maintenance free)	Multitruck Electric - no licence version**
Payload*	up to 500 kg				
Pick up finishing equipment weight	30				
Max. tolerated load on Front axle	390	475	520	520	520
Max. tolerated load on Rear axle	450	690	690	690	690
Loaded trailer (without brakes) max. weight	NA				
Loaded trailer (with brakes) max. weight	NA				

\* Includes load, driver, passenger, finishing equipment, options and accessories weights - Refer to basic version technical data sheet.  
\*\* In France

## Standard equipment

- Basic version equipment
- Tailgate

## Optional equipment

- Presence bell (all electric versions)
- Run time meter (standard in Worker)
- Trim hooks
- Radio CD/MP3/RDS
- Wood floor (combustion engine versions)\*
- Side impact bars
- Rear impact bar
- Flashing beacon
- Roadsign bar (with 2 beacon lights)
- Reflecting tapes
- Diesel additional heating system (all electric versions)
- Reversing buzzer (combustion engine versions)\*
- Cage
- Cage netting
- Cab wired protection

\*standard on electric versions



Cage / Cage netting



Reflecting tapes



Spacious cabine



Rear impact bar



Roadsign bar (with 2 beacon lights)



Side impact bars